

DESIGN GUIDE

Heat producing components currently widely used in electronic and industrial equipment enclosures present the problem of dissipating the heat generated before damage can occur to heat-sensitive parts. In many cases, the problem can be solved by ventilation, using simple air moving devices. However, in more and more applications the available ambient air is too warm or too contaminated to be used for the safe dissipation of the unwanted heat. Under those conditions, the life expectancy and performance of sensitive components may be adversely affected, often causing equipment malfunctions, slowdowns or failures.

In forced convection cooling of enclosures, cooler ambient air is drawn or forced through the components in an enclosure and discharged. When electronic/electrical enclosures are sealed to keep out moisture, dust, dirt and other contaminants, the heat generated by the components is trapped and closed-loop cooling (air conditioner or heat exchanger) is needed to maintain the optimum environment for the components.

This Design Guide/Catalog is not merely a collection of product offerings. It is intended as a design aid to be used as a problem-prevention and problem-solving tool, with an extensive array of equipment and specifications so that the best-suited items can be selected as the solutions for virtually every type of enclosure ventilation or cooling requirement. Refer to the Glossary/Technical Comments on page 15 for support with technical terms and additional design information.

COOLING PRODUCT SELECTION

The KOOLTRONIC philosophy is to specify the smallest, least complex cooling device that will satisfy the requirements of the application.

Forced Ventilation Air Cooling

In clean, non-hazardous environments with acceptable ambient temperatures, a simple forced-air cooling system utilizing ambient air is usually adequate. Combined with a low-cost air filter, such devices generally meet the heat removal needs of typical electronic and electrical equipment.

Closed-Loop Cooling

In harsh environments involving high temperatures, heavy particulates, oil, or chemicals capable of damaging components, ambient air must be kept out of the enclosure. Sealed enclosures are generally used, with closed-loop cooling consisting of two separate circulation systems in a single unit. One system, sealed against the ambient air, cools and recirculates the clean cool air throughout the enclosure. The second system uses ambient air or water to remove and discharge the heat.

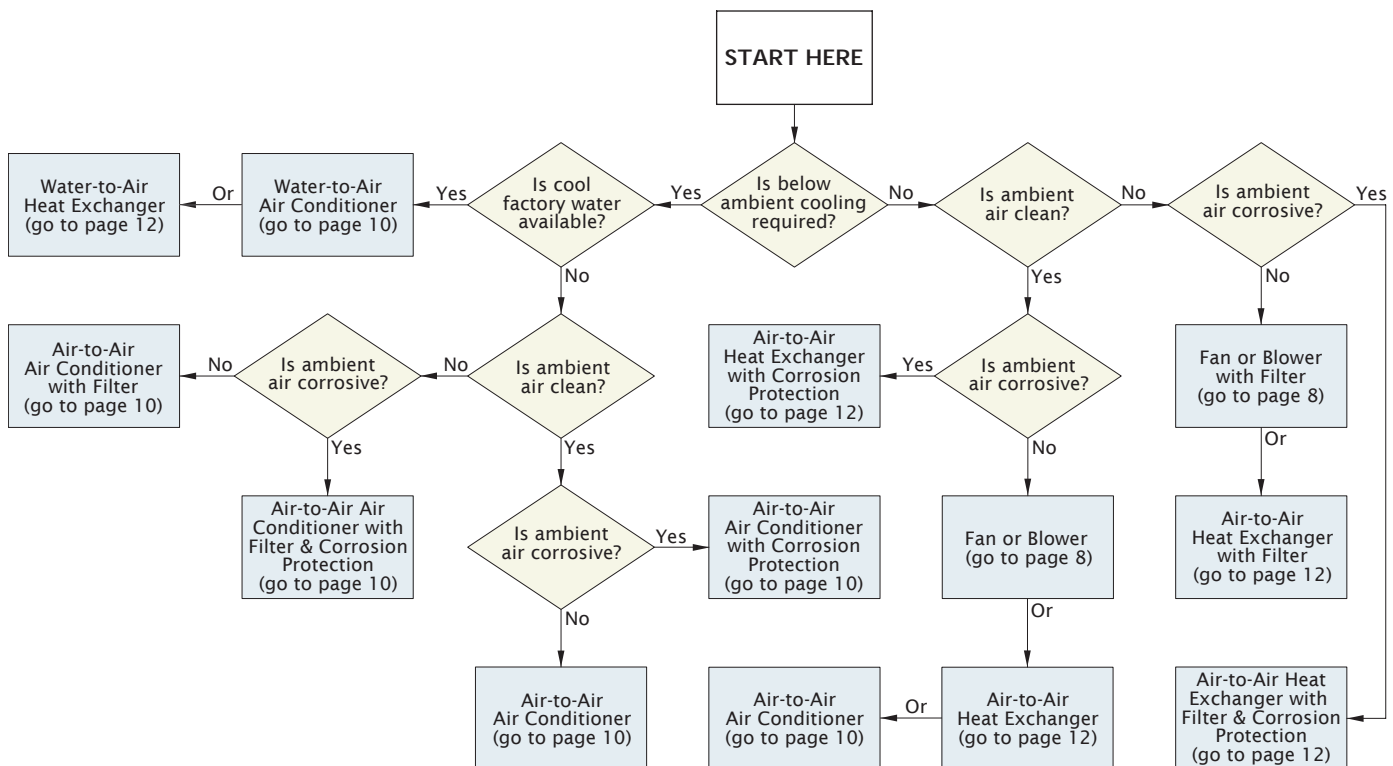

FAN AND BLOWER SELECTION

DETERMINE THE AIRFLOW REQUIRED:

STEP 1: Determine the amount of heat to be removed (in watts). This step is the same procedure as used for the selection of heat exchangers (See Page 12). The example on page 12 identifies 922 watts for the total cooling capacity required, which equals the total heat needed to be dissipated (removed).

STEP 2: Determine the Delta T. This value is described by the formula:
 Delta T = MAXIMUM ALLOWABLE INTERNAL ENCLOSURE TEMPERATURE - MAXIMUM OUTSIDE AMBIENT ($\Delta T = MAIET - MOA$).
 These numbers have already been identified on page 12 in step 2.
 The example used there was 120°F - 110°F = 10°F Delta T.

STEP 3: Plot the values for your applications. On the graph below, locate the watts to be dissipated (922W). Draw a horizontal line over to the diagonal line that represents your Delta T (10°F). Draw a vertical line down. This is the airflow (CFM) needed for your application. In our example the CFM is 365.

Based on standard air density (.075 lbs. per cubic foot), the graph provides quick solutions for the following equations:

Temperature rise in degrees Fahrenheit: $CFM = (3.17 \times P \times 1.25) / \Delta T$

Example: $(3.17 \times 922 \times 1.25) / 10 = 365.34$ CFM

Temperature rise in degrees Celsius (Centigrade): $CFM = (1.76 \times P \times 1.25) / \Delta T$

CFM = Cubic Feet per Minute

P = Power to be dissipated in watts

Delta T = (see step 2 above)

These formulas include a "safety factor" of 25 percent more air than is strictly required by theory. This is expressed by the constant 1.25 in the formulas above.

STEP 4: Select the System. On the flow chart below, select the type of air moving product that you need.

Heat Dissipation Graph

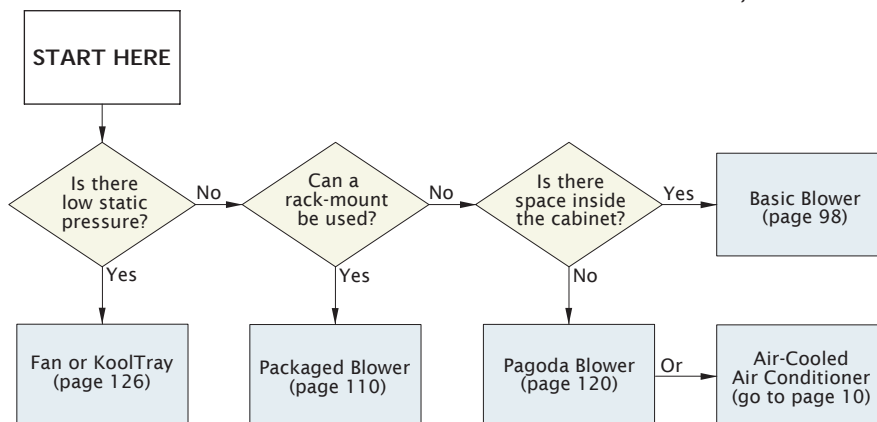
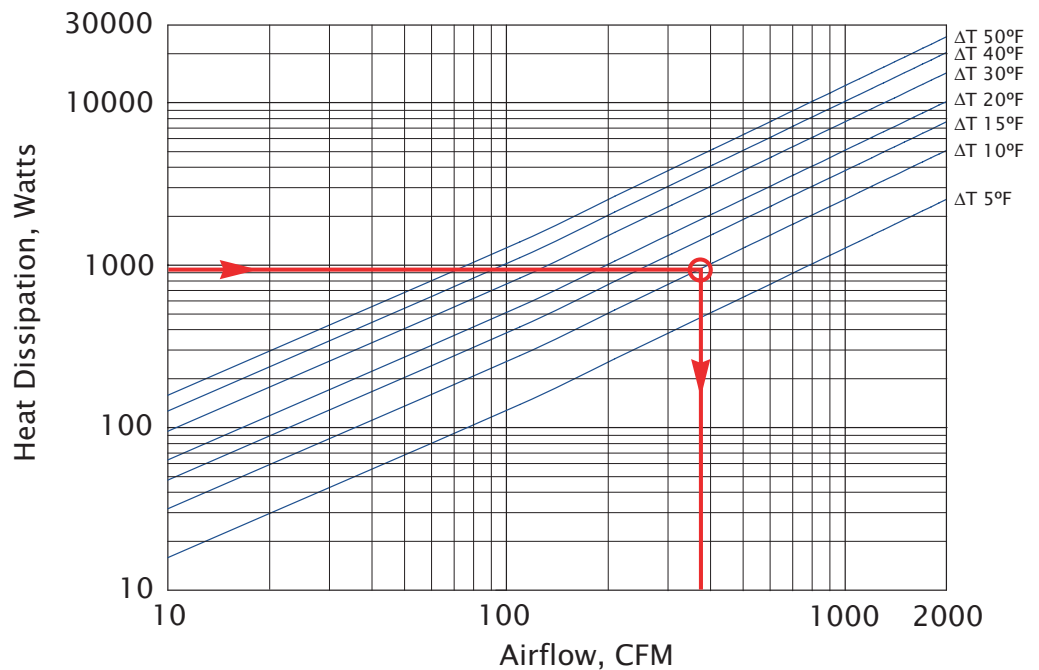

NEMA ENCLOSURE RATINGS

Air conditioners typically carry an agency marking such as UL (Underwriters Laboratories), which designates the environmental hazard from which the contents are being protected. This marking should be matched to the enclosure to be cooled. Typical examples include NEMA 12, (indoor use, protection from dust and dripping liquids), NEMA 3R, (outdoor use and rainproof) and NEMA 4/X (outdoor or indoor use, protection from wash-down and corrosive environments).

Environments:	NEMA 1	NEMA 3R	NEMA 4	NEMA 4X	NEMA 5	NEMA 6	NEMA 6P	NEMA 12	NEMA 13
Kooltronic Offers Solution*	✓	✓	✓	✓	✓			✓	
Indoor use only	✓				✓			✓	✓
Indoor and outdoor use		✓	✓	✓		✓	✓		
Falling liquids and light splashing		✓	✓	✓		✓	✓	✓	✓
Non-hazardous dust, lint, fibers			✓	✓	✓	✓	✓	✓	✓
Washdowns and splashing water			✓	✓		✓	✓		
Oil and coolant seepage								✓	✓
Oil and coolant spraying and splashing									✓
Corrosive agents				✓			✓		
Occasional temporary submersion						✓	✓		
Occasional prolonged submersion							✓		

NEMA 7 and **NEMA 9** enclosures are rated for hazardous locations; both are for indoor use. **NEMA 7** enclosures are designed to contain an internal explosion without causing an external hazard. **NEMA 9** enclosures are designed to prevent the ignition of combustible dust.

* Kooltronic's custom design capabilities offer cooling solutions for situations that fall under these NEMA ratings. We can develop a unique design to meet your particular requirements. Consult with Kooltronic's design and engineering staffs to discuss your heat dissipation problems.

AIR CONDITIONER SELECTION

(for Heat Exchanger applications, see page 12)

DETERMINE THE COOLING CAPACITY REQUIRED:

Air conditioners for cooling electrical enclosures should be sized to provide adequate cooling for the anticipated worst case conditions. This is usually when the ambient is the highest, and also when the electrical loads through the enclosure are at the maximum. However the air conditioner should not be over-sized, as this could result in compressor short cycling. This might cause wide swings in enclosure temperatures.

The total cooling capacity required of the air conditioner includes the:

(A) INTERNAL HEAT LOAD, (B) SOLAR HEAT LOAD and (C) HEAT LOAD TRANSFER.

(A) The INTERNAL HEAT LOAD is the heat generated by the components within the enclosure.

(B) The SOLAR HEAT LOAD is the additional heat due to the sun's rays.

NOTE: Unfortunately the calculation required to properly identify the true Solar Heat Load is too extensive to provide here. Therefore we recommend you call the Kooltronic Sales Department. They have access to a computer program that will provide an accurate answer after a few simple questions. If you have an outdoor application, do not ignore the solar heat load. It can be substantial.

(C) The HEAT LOAD TRANSFER is the additional heat that is added through the walls of the enclosure. (This statement assumes the outside ambient is warmer than the air inside the enclosure.)

NOTE: Refer to the Glossary/Technical Comments section for explanations of technical terms and more information about Engineering issues.

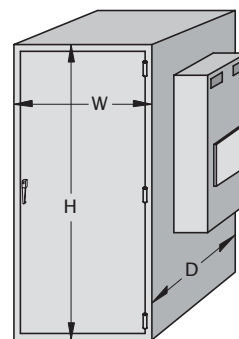

STEP 1: Calculate the Internal Heat Load by using the Incoming / Outgoing Power Test Method

The Internal Heat Load can be determined by measuring the electrical energy that stays inside the enclosure. It is assumed that this energy is eventually transformed into waste heat. To measure this electricity, the current going In and Out must be measured in amps. The voltage of this current is also important. It is critical that all wires entering and leaving the enclosure must be included. Typically, a voltmeter and a clamp-on type ammeter should be used. The data must be recorded during the time when the current flow is the highest. A qualified technician is recommended for safety and accuracy reasons.

The Internal Heat Load = $3.413 \times \text{Voltage} (\text{Current IN} - \text{Current OUT})$.

NOTE: This equation is derived from: $3.413 \text{ BTU} = 1 \text{ Watt}$ and watts = volts x amps. For example, if you measured 220 volts, 40 amps IN, 35 amps OUT, the Internal Heat Load = $3.413 \times 220 \times (40 - 35) = 3754 \text{ BTU/H}$. Consult with an Electrical Engineer if 3 phase power or a very complicated circuit is involved.

STEP 2: Calculate the Heat Load Transfer

The heat load transfer is the additional heat added to the enclosure through the walls from the surrounding ambient. This is identified by the formula:

Heat Load Transfer = $(\text{Max. Outside Ambient} - \text{Max. Allowable Internal Enclosure Temperature}) \times \text{Surface Area} \times 1.25$
 $\text{HLT} = (\text{MOA} - \text{MAIET}) \times \text{SA} \times 1.25$

NOTE: 1.25 is a constant for metal enclosures. Use 0.8 for a plastic enclosure or 0.6 for an insulated enclosure.

The Maximum Outside Ambient (MOA) is the warmest room temperature surrounding the enclosure that might happen all year long. The MOA might be as high as 130°F in an industrial equipment room. The Maximum Allowable Internal Enclosure Temperature (MAIET) should not exceed the heat tolerance specification of the most sensitive component in your system. The MAIET might not be allowed to go over 90°F per the enclosure's component specifications.

The Surface Area (SA) is calculated as follows:

Surface Area = $(H \times W) + (H \times W) + (H \times D) + (H \times D) + (W \times D)$

H = height in feet, W = width in feet, D = depth in feet

For example; H = 4, W = 2, D = 3: Surface area = $(4 \times 2) + (4 \times 2) + (4 \times 3) + (4 \times 3) + (2 \times 3) = 46 \text{ sq.ft.}$

Therefore in our example, the HLT = $(130^\circ\text{F} - 90^\circ\text{F}) \times 46 \times 1.25 = 2300 \text{ BTU/H}$

STEP 3: Calculate the Total Cooling Capacity Required

The total cooling capacity required to cool your equipment is equal to:

Internal Heat Load + the Heat Load Transfer. The example: $3754 + 2300 = 6054 \text{ BTU/H}$

AIR CONDITIONER PERFORMANCE CHART EXPLANATION:

In the air conditioner section there are detailed specifications for each cooling system and a performance chart similar to the one shown below. Use the charts to verify that the correct unit, with the proper cooling capacity, has been selected.

Example:

- The maximum ambient temperature is 110°F.
 - The maximum enclosure air temperature is 100°F.
 - The minimum air conditioner capacity is 8,000 BTU/H.
1. Locate the 110°F requirement at the bottom of the example chart.
 2. Follow the vertical line up until it intersects with the 100°F maximum enclosure air temperature.
 3. Follow the horizontal line to identify the actual cooling capacity that the unit will deliver at these conditions.
 4. In this case, the unit will deliver approximately 8,000 BTU/H which is acceptable. If the unit's capacity under this condition was below 8,000 BTU/H, select another model with more capacity. If the capacity was significantly above the 8,000 BTU/H requirement, the next size smaller model should be selected.

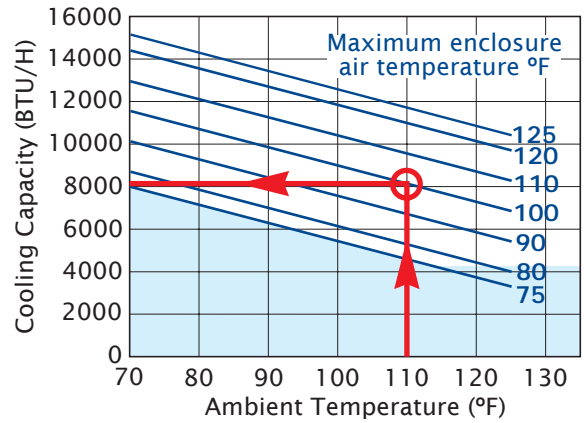

SELECT THE APPROPRIATE AIR CONDITIONER PRODUCT LINE:

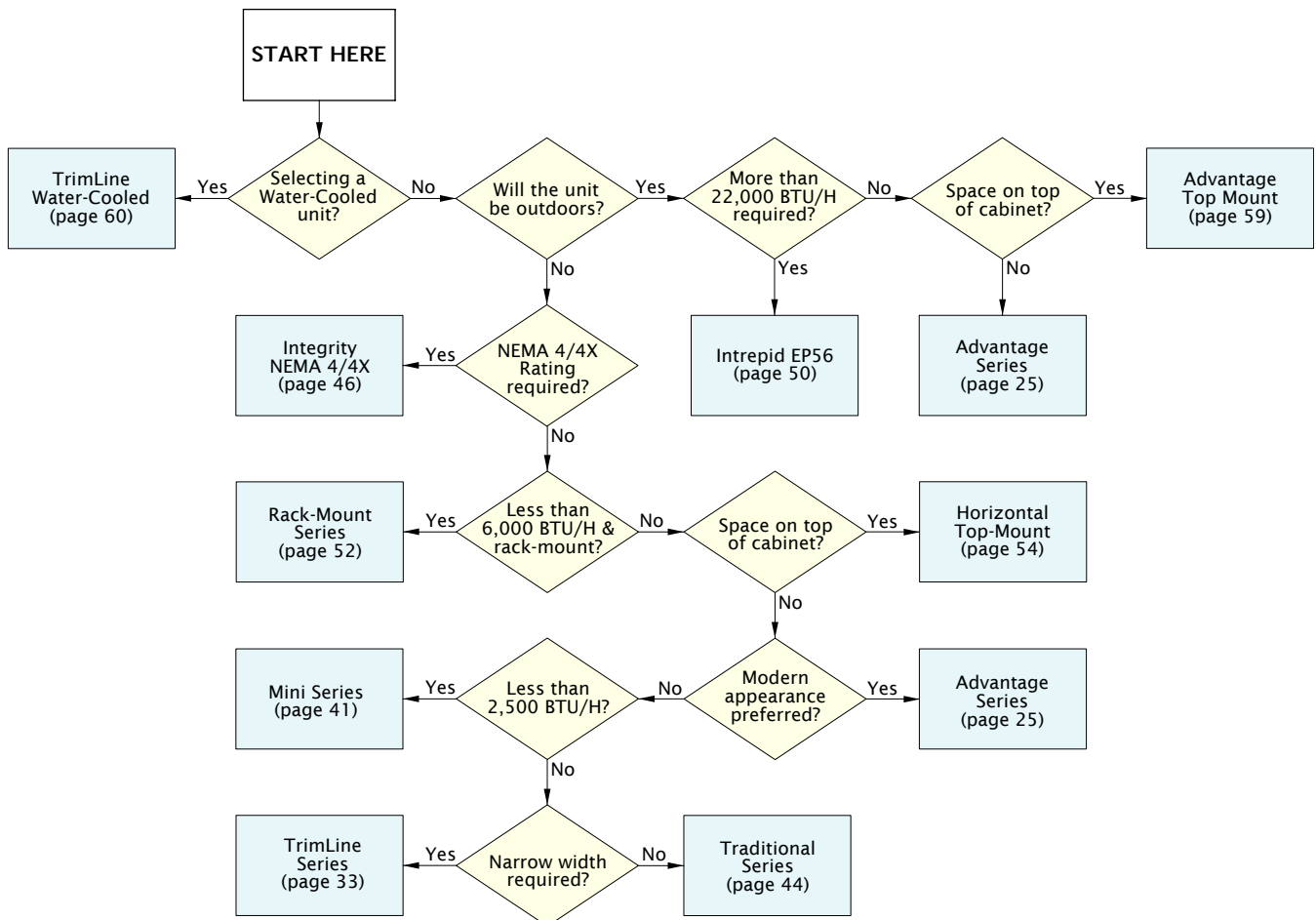

HEAT EXCHANGER SELECTION

(for Air Conditioner applications, see page 10)

DETERMINE THE COOLING CAPACITY REQUIRED:

Heat exchangers for cooling electronic/electrical enclosures should be sized to provide adequate cooling for the anticipated worst case conditions. This is usually when the ambient is the highest, and also when the electrical loads through the enclosure are at the maximum. The outward portion of the heat exchanger uses either water or ambient air in the cooling process. The heat exchanger cannot cool the cabinet below the temperature of that water (or air). The greater the temperature differential between 1) the hot internal enclosure air and 2) the cooling water (or air), then, the higher the capacity of any heat exchanger will be. Conversely the smaller the temperature differential available in an application, the larger the heat exchanger size needs to be to achieve the goal.

The total cooling capacity required of the heat exchanger includes the:

(A) INTERNAL HEAT LOAD, (B) SOLAR HEAT LOAD and (C) HEAT LOAD TRANSFER.

(A) The INTERNAL HEAT LOAD is the heat generated by the components within the enclosure.

(B) The SOLAR HEAT LOAD is the additional heat due to the sun's rays.

NOTE: Unfortunately the calculation required to properly identify the true Solar Heat Load is too extensive to provide here. Therefore we recommend you call the Kooltronic Sales Department. They have access to a computer program that will provide an accurate answer after a few simple questions. If you have an outdoor application, do not ignore the solar heat load. It can be substantial.

(C) The HEAT LOAD TRANSFER is the heat that is lost through the walls of the enclosure. (This statement assumes the outside ambient is cooler than the air inside the enclosure.)

NOTE: Refer to the Glossary/Technical Comments section for explanations of technical terms and more information about Engineering issues.

STEP 1: Calculate the Internal Heat Load by using the Incoming / Outgoing Power Test Method

The Internal Heat Load can be determined by measuring the electrical energy that stays inside the enclosure. It is assumed that this energy is eventually transformed into waste heat. To measure this electricity, the current going In and Out must be measured in amps. The voltage of this current is also important. It is critical that all wires entering and leaving the enclosure must be included. Typically, a voltmeter and a clamp-on type ammeter should be used. The data must be recorded during the time when the current flow is the highest. A qualified technician is recommended for safety and accuracy reasons.

The Internal Heat Load = $3.413 \times \text{Voltage} (\text{Current IN} - \text{Current OUT})$

NOTE: This equation is derived from: $3.413 \text{ BTU} = 1 \text{ Watt}$ and $\text{watts} = \text{volts} \times \text{amps}$. For example, if you measured 220 volts, 40 amps IN, 35 amps OUT, the Internal Heat Load = $3.413 \times 220 \times (40 - 35) = 3754 \text{ BTU/H}$. Consult with an Electrical Engineer if 3 phase power or a very complicated circuit is involved.

STEP 2: Calculate the Heat Load Transfer

The heat load transfer is the additional heat lost through the enclosure walls to the surrounding ambient. This is identified by the formula:

Heat Load Transfer = $(\text{Max. Outside Ambient} - \text{Max. Allowable Internal Enclosure Temperature}) \times \text{Surface Area} \times 1.25$
 $\text{HLT} = (\text{MOA} - \text{MAIET}) \times \text{SA} \times 1.25$

NOTE: 1.25 is a constant for metal enclosures. Use 0.8 for a plastic enclosure or 0.6 for an insulated enclosure.

The Maximum Outside Ambient (MOA) is the warmest room temperature surrounding the enclosure that might happen all year long. The MOA might be as high as 110°F. The Maximum Allowable Internal Enclosure Temperature (MAIET) should not exceed the heat tolerance specification of the most sensitive component in your system. The MAIET might not be allowed to go over 120°F per the enclosure's component specifications.

The Surface Area (SA) is calculated as follows: $\text{Surface Area} = (H \times W) + (H \times W) + (H \times D) + (H \times D) + (W \times D)$. H = height in feet, W = width in feet, D = depth in feet. For example: H = 4, W = 2, D = 3: $\text{Surface area} = (4 \times 2) + (4 \times 2) + (4 \times 3) + (4 \times 3) + (2 \times 3) = 46 \text{ sq. ft}$. Therefore in our example, the $\text{HLT} = (110^\circ\text{F} - 120^\circ\text{F}) \times 46 \times 1.25 = -575 \text{ BTU/H}$.

STEP 3: Calculate the Total Cooling Capacity Required

The total cooling capacity required to cool your equipment is equal to: Internal Heat Load + Heat Load Transfer. The example: $3754 + (-575) = 3179 \text{ BTU/H}$. The performance of Heat Exchangers is expressed in WATTS/°F. Therefore you will need to convert the BTUs to WATTS, so multiply by .29. The example; $3179 \text{ BTUs} \times .29 = 922 \text{ watts} = \text{Total Cooling Capacity Required}$.

STEP 4: Selecting the Heat Exchanger Performance Rating

Calculate the Temperature Differential: $\text{MAIET} - \text{MOA}$. Use the numbers select in Step 2: $120^\circ\text{F} - 110^\circ\text{F} = 10^\circ\text{F}$.

Divide the Total Cooling Capacity Required from Step 3 by the Temperature Differential to reach the required Watts/°F for this application. Example: $922 \div 10^\circ\text{F} = 92.2 \text{ Watts/}^\circ\text{F}$.

NOTE: If the Temperature Differential in step 3 can be increased to 15°F (by changing the Maximum Outside Ambient and/or the Maximum Allowable Internal Enclosure Temperature) then a smaller Heat Exchanger (rated at 61 Watts/°F) can be used. **NOTE:** If Heat Exchanger is determined to be inadequate for your application see Air Conditioner Selection Guide on page 10 or contact Kooltronic at (609) 466-3400.

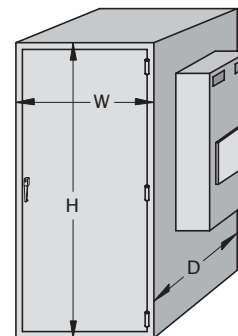



HEAT EXCHANGER CAPACITY IN WATTS

TEMPERATURE DIFFERENCE

CABINET HOT AIR minus COOLER OUTSIDE AMBIENT AIR (or WATER)

HEAT EXCHANGER PERFORMANCE RATING (WATTS/°F)	5	10	15	20	25	30	35	40	45	50
8	40	80	120	160	200	240	280	320	360	400
10	50	100	150	200	250	300	350	400	450	500
16	80	160	240	360	400	480	560	640	720	800
17	85	170	255	340	425	510	595	680	765	850
18	90	180	270	360	450	540	630	720	810	900
19	95	190	285	380	475	570	665	760	855	950
21	105	210	315	420	525	630	735	840	945	1050
22	110	220	330	440	550	660	770	880	990	1100
26	130	260	390	520	650	780	910	1040	1170	1300
27	135	270	405	540	675	810	945	1080	1215	1350
28	140	280	420	560	700	840	980	1120	1260	1400
30	150	300	450	600	750	900	1050	1200	1350	1500
33	165	330	495	660	825	990	1155	1320	1485	1650
37	185	370	555	740	925	1110	1295	1480	1665	1850
42	210	420	630	840	1050	1260	1470	1680	1890	2100
44	220	440	660	880	1100	1320	1540	1960	1980	2200
52	260	520	780	1040	1350	1560	1820	2080	2340	2600
54	270	540	810	1080	1350	1620	1890	2160	2430	2700
55	275	550	825	1100	1375	1650	1925	2200	2475	2750
56	280	560	840	1120	1400	1680	1960	2240	2520	2800
57	285	570	855	1140	1425	1710	1995	2280	2565	2850
65	325	650	975	1300	1625	1950	2275	2600	2925	3250
66	330	660	990	1320	1650	1980	2310	2640	2970	3300
68	340	680	1020	1360	1700	2040	2380	2720	3060	3400
74	370	740	1110	1480	1850	2220	2590	2960	3330	3700
79	395	790	1185	1580	1975	2370	2765	3160	3555	3950
88	440	880	1320	1760	2200	2640	3080	3520	3960	4400
91	455	910	1365	1820	2275	2730	3185	3640	4095	4550
96	480	960	1440	1920	2400	2880	3360	3840	4320	4800
118	590	1180	1770	2360	2950	3540	4130	4720	5310	5900

TO CONVERT WATTS TO BTU'S, MULTIPLY BY 3.413
1 WATT = 3.413 BTU'S

The boxes above highlighted in yellow demonstrate the benefit of having cooler ambient air available. For example, if you need to eliminate 500 Watts and have 5 degrees of temperature difference, you will need a heat exchanger rated at 118 Watts/° F. But, if ambient air can be reduced by 5°, or 5° warmer cabinet temperature is acceptable, then the temperature difference changes to 10°F. This will allow you to select a smaller heat exchanger rated at 55 Watts/° F.

SELECT THE APPROPRIATE HEAT EXCHANGER PRODUCT LINE:

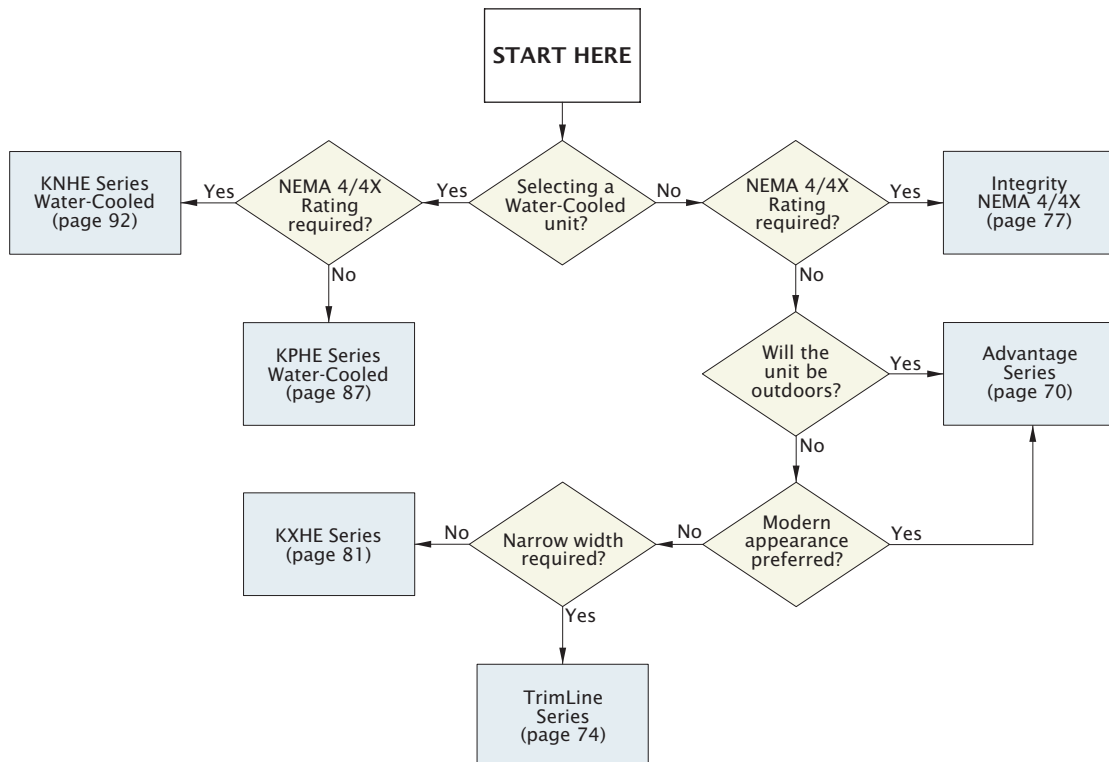

ENCLOSURE COOLING TIPS

THINK ABOUT COOLING...EARLY! - Cooling needs should be evaluated early in the design process. Nearly all systems require some degree of forced cooling. Early estimates of the location of components in the cabinet, the heat to be dissipated and the amount of space needed for the cooling device will save time, trouble and expense.

FORCED VENTILATION VS. CLOSED-LOOP COOLING - Keep it simple. If ambient air is cool and clean enough, use it. It's free. If the ambient is too hot, dirty or corrosive, a closed-loop system is needed. A heat exchanger is usually a lower-cost choice than an air conditioner. See if it will do the job. Don't over-cool. Don't oversize the cooling equipment.

FAN OR BLOWER? - Propeller fans are designed to move large volumes of air at low static pressure. Blowers are used in higher static pressure applications and are at maximum efficiency when operating near their peak static pressure. Figure 2 shows their relative operating characteristics.

PRESSURIZE, DON'T VACUUMIZE! - Pressurization of the cabinet is far more desirable than drawing the air out. Plan to pump filtered air INTO the cabinet, to gain the advantage of using cracks between panels, around doors or other small openings as part of the exhaust area rather than as sources for the intake of dust and dirt. If pressurization is impossible and a fan or blower must be used to exhaust the enclosure, a filter at the air inlet is recommended.

KEEP IT CLEAN - Nothing is more important than CLEAN filters. Clogged filters restrict airflow and cause motors, compressors, etc. to work harder and fail prematurely. Timely filter servicing is vital to your system.

KEEP INLET AND EXHAUST AIR FAR APART - Be sure that all of the exhaust area is located downstream, as far as possible from the air inlet and beyond all heat-producing components. An open-base cabinet sitting only one-quarter inch off the floor can waste a substantial percentage of cooling air even if the air is directed upward initially. A properly planned air path will avoid all "short circuits" or losses by forcing the cool supply air to pass through the components that are to be cooled before reaching the exhaust area. This will allow for a maximum of cooling efficiency.

LET NATURE HELP - Cooling air should enter the enclosure from as low as possible and leave the enclosure from above the highest hot component. Thus, the forced air flows upward through the heat-producing components and adds to the natural buoyancy of the heated air.

A "BOOSTER" CAN SAVE SPACE AND COST - A booster fan located downstream or at the outlet can draw added cooling power through densely packed components. It could permit the use of a smaller, quieter packaged blower than originally indicated, allowing more panel space for other uses.

ENTERING AIR NEEDS EXIT ROOM - The cross-section area of the airstream throughout the flow path in the cabinet should be at least equal to the effective area of the air intake. If this ratio is less, "choking" of the delivered air may result. The table shown on the right gives the recommended area which should be available for discharge.

For intake and exhaust grille and filter grille assemblies, see the Accessories and Options sections.

USE DUCTS FOR EVEN COOLING - If the maintenance of an even temperature from top to bottom of the enclosure is important, ducts along the sides of the enclosure offer an ideal solution. Multiple duct outlets allow precise control of the location and quantity of air delivered.

COMPONENT LOCATION - Where possible, locate heat sensitive electrical components toward the bottom of the enclosure, since the warmest air temperatures will be at the top. Maintain adequate spacing between components within the enclosure to minimize airflow restriction.

BAFFLES SOMETIMES WORK WONDERS - At times, an excessively hot component or an isolated area in the enclosure presents a problem in an otherwise well-cooled system. A baffle to channel air across the location is often the best solution.

VIBRATION ISOLATION - Neoprene vibration isolators minimize the possibility of trouble associated with vibration. All portions of a system will respond to periodic forces in varying degrees. This excitation can occur regardless of the balance or design of the air-moving equipment, since any given construction could be in resonance with any of the driving forces in the blower motor. If the sympathetic vibration level is unacceptable, slight weight change or redistribution will usually alleviate the problem.

CALL KOOLTRONIC FOR HELP - For help with your design problems or to resolve questions, give us a call.

RELATIVE OPERATING CHARACTERISTICS OF FANS AND BLOWERS

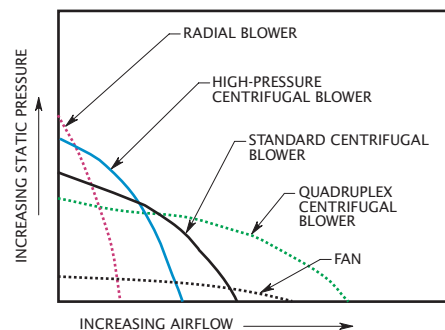

19-inch Front Panel Intake		
3.50" [88.9mm]	34 sq. in. [219 sq. cm]	
5.25" [133.4mm]	51 sq. in. [329 sq. cm]	
7.00" [177.8mm]	68 sq. in. [439 sq. cm]	
8.75" [222.3mm]	85 sq. in. [548 sq. cm]	
10.50" [266.7mm]	102 sq. in. [658 sq. cm]	

Circular Fan Intake		
6.50" [165.1mm]	33 sq. in. [213 sq. cm]	
8.00" [203.2mm]	50 sq. in. [323 sq. cm]	
9.00" [228.6mm]	64 sq. in. [413 sq. cm]	
9.50" [241.3mm]	71 sq. in. [458 sq. cm]	
10.00" [254.0mm]	78 sq. in. [503 sq. cm]	

AIR CONDITIONER An air conditioner uses a refrigerant system and an air moving system to cool air.

A typical “Special Purpose Air Conditioner” operates as follows: Heat is transferred from the enclosure components by circulating air around and through them, the air is then cooled, dehumidified and returned to the enclosure without the admission of air from the outdoors. The heat is removed from this air within the air conditioner and discharged by means of a vapor compression refrigeration cycle. This takes place in a hermetically sealed system, utilizing either an air-cooled or water-cooled condenser coil. A schematic of a typical air conditioner is illustrated below.

Typical ADVANTAGE Series Air Conditioner

Typical TRIMLINE Series Air Conditioner

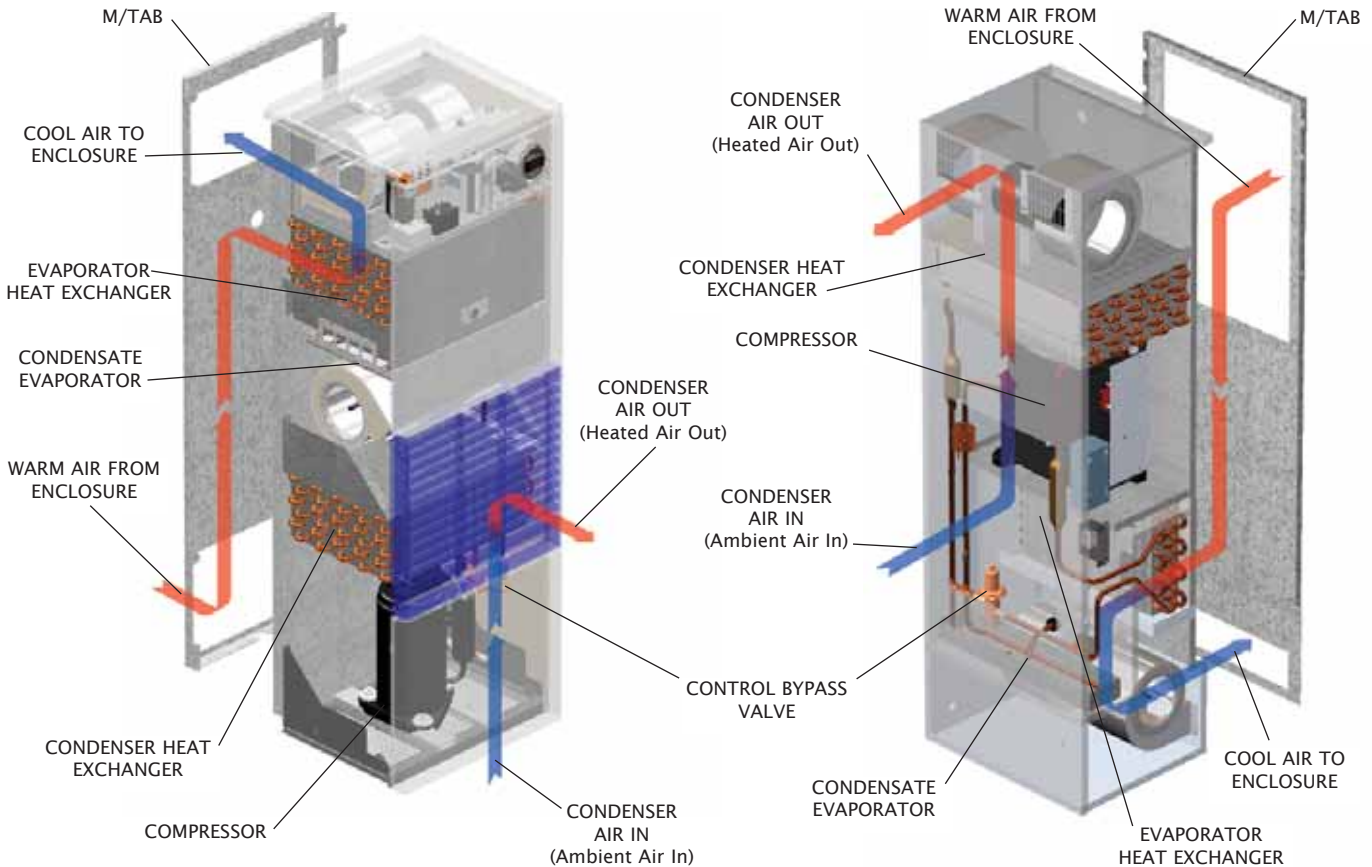

The compressor forces refrigerant, in vapor form, into the condenser coil where it is cooled by ambient air. As it cools, the refrigerant condenses into a liquid, which is passed through a filter to remove impurities and excess moisture. The liquid refrigerant flow is metered by a thermostatic expansion valve (or capillary tube), to control its flow into the evaporator coil.

The liquid refrigerant enters the evaporator and begins to evaporate (vaporize) into a gas. As the hot air from the enclosure passes through the evaporator coil, the heat is transferred to the refrigerant, converting the refrigerant to vapor. High levels of humidity present in the air are removed by condensation; the water is drained to the outside or re-evaporated into the outside air. This cool, dehumidified air is then returned to the cabinet. After the heat is transferred to the refrigerant in the evaporator, the refrigerant passes into an accumulator, where any remaining liquid is separated. The gas then returns to the compressor to repeat the cycle in a continuous process.

Control of the system is generally kept simple. When power is applied to the air conditioner the evaporator blower (or fan) starts and runs continuously. If the temperature within the enclosure is high, the condenser blower and the compressor turn on, operating until the thermostat setting is reached. The thermostat is used as a low limit setting. This is typically 75°F, the point at which the compressor and the condenser blower is turned off. Air within the enclosure continues to be circulated by the evaporator blower, picking up heat from the components within the cabinet. The thermostat has a differential setting that is typically 12-15 degrees above the low limit setting. When the air circulated within the enclosure rises by this amount (about 90°F), the compressor and condenser blower turn back on, reducing the cabinet internal air temperature once again. Therefore, it would be normal at start up for the internal temperature to rise to this 90°F temperature before the cooling process would begin. As the air cools, a

balance of temperature within the enclosure is reached. Ideally the compressor and condenser blower continue to run most of the time until the heat load changes.

It is important to understand that enclosure cooling is not “comfort” cooling as found in homes and buildings. Heat producing power and control components are typically limited to maximum enclosure air temperatures of 100°F to 110°F. The actual component surface temperatures are higher. Maintaining enclosure temperatures at excessively low settings often becomes problematic. Condensation may form on live electrical surfaces if their temperature falls below the dew point of the air. Subsequent corrosion or electrical safety becomes a serious issue.

Air conditioners are required where the equipment operating temperature must be kept at or lower than the ambient room temperature, and/or the cabinet must be sealed from oil, dust, fumes and other contaminants.

Specially designed air conditioners protect the components and furnish the required cooling. Such air conditioners employ hermetic refrigeration systems with customized controls. They provide enclosure and air-path geometries for direct installation to the equipment cabinet and accomplish the following:

1. Isolate the interior of the equipment enclosure from ambient conditions
2. Cool the air within the enclosure to the optimum temperature for the sensitive components
3. Circulate the air within the enclosure to equalize temperature and increase heat transfer from hot components
4. Automatically vary cooling rate to maintain close control of equipment temperature
5. Reduce humidity harmful to sensitive components

Air conditioners that are used to cool enclosed equipment differ radically from room air conditioners. In the area of temperature control, for example, most electronic systems are adversely affected by large line transients typical of air conditioner compressor cycling. Electronics also exhibit sensitivity to electromagnetic interference caused by thermostat contacts. The control system of an air conditioning package must be designed accordingly.

In addition, the field experience of many compressor manufacturers has indicated that the frequent start/stop cycling, typical of standard Air Conditioner operation, shortens compressor reliability.

These factors have led to the development of techniques for close control of internal temperature over a wide range of ambient conditions, without turning the refrigeration compressor on and off and without employing electrically-controlled solenoid valves.

Recent developments in temperature requirements for enclosed components have led to the addition of adjustable Low Temperature Control thermostats in all KOOLTRONIC Air Conditioners to prevent over-cooling. EMI/RFI suppressors are included to control the line transients associated with compressor cycling and thermostat operation.

AIR CONDITIONERS (AIR-COOLED) Heat removed from the enclosure is discharged by circulating the ambient air through the condenser coil and returning the heated air to the ambient. This is the most common form of small air conditioning systems.

AIR CONDITIONERS (WATER-COOLED) Intended primarily for extreme operating conditions of high-ambient temperatures or severe contaminants, these units utilize water as the medium for heat dissipation. The heat is absorbed by cool water circulating through a coaxial condenser coil, following which the heat-laden water is discharged or recirculated after cooling.

AMBIENT The environment surrounding the product. The word Ambient is typically used to describe the temperature, humidity, air cleanliness or quality including dust and possibly any other harsh weather condition. (See Corrosive Atmosphere)

AMBIENT TEMPERATURE RANGE Most KOOLTRONIC Air Conditioners are designed to operate at ambient temperatures ranging from 50°F to 131°F. Optional Low Ambient Kits allow operation in ambient temperatures as low as 0°F.

Maximum operating ambient temperature decreases linearly with altitude at the rate of 3°F per 1,000 feet between 2,500 and 7,500 feet, where maximum operating ambient temperature is 110°F. The ability to operate at high ambient temperatures permits KOOLTRONIC Air Conditioners to be installed indoors in close proximity to furnaces and other heat-producing equipment.

For applications in ambient temperatures higher than the rated maximum, consultation with the KOOLTRONIC Engineering Department often provides the solution.

AUTOMATIC EXPANSION VALVE (AEV) A refrigerant metering device that provides the same function as a capillary tube (See Capillary), but can provide a variable flow rate to match different load conditions. (See Temperature Control)

BLOWER or **BLOWER WHEEL** or **SQUIRREL-CAGE BLOWER** An air moving device typically used to move air against medium to high static pressure systems. Blowers are designed to operate against higher static pressures than fans. Packaged blowers provide compact, filtered, rack-mounted cooling in a variety of airflow configurations.

BLOWERS (VARIABLE SPEED) The optimum open-cycle system for use in contaminated environments combines appropriate air filters and cooling-effect detectors with a variable speed blower that adjusts its operating speed to provide the desired cabinet air temperature, as sensed at some point within the enclosure. Since blower air delivery is directly proportional to motor shaft speed, airflow rate can be adjusted to a minimum compatible with a clean air filter and low ambient temperature. Should ambient temperature increase or the filter clog with contaminants, the sensor and controls would demand an increase in motor speed until the new conditions were satisfied.

The variable speed blower is self-adaptive to changes in ambient temperature, air density, line voltage, power dissipation in the enclosure, and to the degree of filter-loading. Since the blower operates at the minimum speed and air delivery compatible with cooling, both power consumption and the rate of contaminant accumulation on filter surfaces is greatly reduced, compared to a constant speed blower designed to satisfy worst-case conditions. This increases filter life and reduces filter maintenance to a minimum. Conversely, as the filter loads, blower air delivery could increase to levels beyond those that would be obtained under constant speed conditions. However, cost must be considered.

BTU/H British Thermal Unit per Hour is a unit of measure for heat. Heat is also commonly measured in watts: (1 BTU/H = .29 watts)

CAPILLARY A copper tube with a very small inside diameter. Its function in the refrigerant system is to separate the High Pressure (condenser) side from the Low Pressure (evaporator) side, by providing a calibrated restriction and a resulting pressure drop.

CFM Cubic Feet per Minute - A CFM is a unit of measure for air volume.

COIL An industry term for a device intended to transfer heat. The typical coil is constructed of aluminum fins and copper tubing.

COOLING (CLOSED LOOP) An industry term used to describe a cooling process that reconditions (reuses) the air inside a chamber. The purpose of this system is to prevent contamination from entering the chamber. Closed loop cooling is recommended only when open loop cooling cannot be used.

Many applications using sophisticated electronic/electrical components require a closed-loop cooling system to dissipate heat buildup without introducing outside contaminated air. Closed-loop cooling is required when equipment is operated in hostile environments containing dirt, oil, humidity or corrosives, which adversely affect the performance or ultimate survival of the components. The presence of airborne particulate matter compounds the difficulty of controlling the temperature of the equipment in the enclosure.

Air conditioners and water to-air heat exchangers provide the greatest capacity to transfer heat in closed loop conditions. They have the unique ability to maintain a lower than ambient temperature and reduce the humidity within the controlled space. It is important to note that enclosure design temperatures may exceed the ambient temperatures, yet be below the electronic components' design limits.

Where maximum internal cabinet design temperatures cannot be maintained using open loop ambient air cooling, closed loop devices need to be considered. Air to air heat exchangers, water to air heat exchangers and air conditioning units are able to cool a confined amount of air within an enclosure.

In harsh environments involving high temperatures, heavy particulates, oil, or chemicals capable of damaging components, ambient air must be kept out of the enclosure. Sealed enclosures are generally used, with closed-loop cooling consisting of two separate circulation systems in a single unit. One system, sealed against the ambient air, cools and recirculates the clean cool air throughout the enclosure. The second system uses ambient air or water to remove and discharge the heat.

COOLING (OPEN LOOP) An industry term used to describe a cooling process that replaces the air inside a chamber with "fresh" cooler air from outside the chamber.

Open loop cooling is the most commonly used process when the available air supply is cool enough and clean enough to provide the required heat removal. (See Cooling (Closed Loop))

Open loop ventilation uses ambient air to remove the heat, and may consist of small muffin type fans that exhaust or supply an electrical cabinet, with optional filters to prevent airborne aerosols and dust from entering the cabinet. The fans have the advantage of utilizing a minimum of cabinet space and will move a substantial volume of air where flow is virtually unimpeded. Cost and complexity is minimized. Where density of components impedes airflow, packaged blowers or motorized impellers may be arranged to operate against these higher static pressures. With a rack enclosure, supplemental fan trays may be used to spot cool or supplement other air-moving devices.

Where maximum internal cabinet design temperatures cannot be maintained using open loop ambient air cooling, closed loop devices need to be considered.

COMPRESSOR is the main component in a refrigerant system. Inside our compressors are a motor and a pump that circulates the refrigerant through the rest of the system.

CONDENSATION The process in nature that causes water (condensate) to be removed from the air, and form on a cold surface. This is commonly seen on the outside of a glass of ice water, or dew on grass in the morning.

High ambient relative humidity does not affect the rated capacities of KOOLTRONIC Air Conditioners. They are designed for installation on reasonably tight enclosures of relatively limited internal volume.

Normally, only sensible heat loads are imposed on the air conditioner. Even at an ambient temperature of 95°F and a relative humidity of 100%, the air within a typical electronic equipment enclosure 2.5 feet square and 6 feet high will contain only a small amount of water in vapor form. As the temperature of the air being circulated within the enclosure is reduced from 95°F to 70°F, the water will be condensed quickly in the evaporator heat exchanger and be disposed of through the drain in the condensate tray at the bottom of the air conditioner.

Unless the enclosure is totally sealed, some slow invasion of ambient air will take place through cracks and seams in the cabinetry and the front panels. However, even at ambient relative humidities of 100%, the infiltration rate is normally so small that the effect on cooling capacity of latent heat of water vapor condensation in the infiltrating air is negligible.

Cooling performance of the air conditioner is reduced if its capacity is used for the condensation of excessive moisture. This occurs if the enclosure is poorly sealed or is open for long periods, under high humidity conditions. A continuous flow of condensate denotes that these adverse conditions are present and should be remedied immediately.

CONDENSER The hot section of the refrigerant system that removes the waste heat away from the refrigerant system. This is commonly accomplished with either air or water to carry away the heat. This component is called a condenser, because the refrigerant inside is changing state from a gas to a liquid (condensing).

CORROSIVE ATMOSPHERES Corrosive environments, such as those found in chemical plants and in industries where processes result in harsh chemical by-products, usually preclude the use of filtered ambient air for forced convection cooling. Corrosives generally cannot be filtered out by normal filtration methods. Scrubbing techniques that must be used to rid air of corrosives are complex, costly and often not satisfactory.

For such applications, the cooling method requires isolation of the sensitive components subject to damage from the offending substances. The solution is usually closed-loop cooling - heat exchangers or air conditioners - which consists of two separate circulation systems in a single unit. One recirculates clean cooling air through the electronics within the sealed enclosure, while the other discharges the heat removed from the cabinet to the ambient air or into water for removal.

If the corrosive atmosphere is within an acceptable temperature range, air-to-air heat exchangers can be used to provide cooling for equipment enclosures. When both high ambient temperatures and corrosives are present, either air conditioners or water-to-air heat exchangers must be employed to cool the hot components.

Regardless of the cooling apparatus chosen, it must be constructed of appropriate corrosion-resistant materials, or be treated with corrosive-resistant coatings, to ensure long, trouble-free operation under the conditions to be encountered.

Care should be taken to review the particular conditions involved. In most cases, a system can be designed to meet specific requirements at moderate cost.

DEW POINT The surface temperature at which condensate (water) will form as related to the air temperature and air humidity. (See Condensation)

ELECTROMAGNETIC INTERFERENCE (EMI) Electrical “noise” that is accidentally generated by electrical products and interferes with the normal operation of other audio and visual equipment.

EVAPORATOR The section of a refrigerant system that operates colder than the ambient. This component is called an evaporator, because the refrigerant inside is changing state from a liquid to a gas (evaporating).

FAN or **PROPELLER FAN** An air moving device typically used to move high volumes of air against low static pressure systems. Fans occupy minimal cabinet space and will move a substantial volume of air where flow is virtually unimpeded. Packaged fans can be used for filtered panel or rack-mounted cooling in such applications.

FILTRATION Filtration of contaminated air can be accomplished in some installations to permit forced convection cooling of electronic equipment. Generally, contamination can be broken down into two major categories: airborne particulate matter and corrosives.

In most cases, particulate matter can be filtered out and the air made safe for the cooling of heat-producing equipment. However, removal of corrosives by filtration generally requires processes that are too costly and/or too restrictive to airflow. Therefore, isolation of the enclosure contents is usually necessary.

Careful consideration must be given to the type and severity of the conditions to be encountered. Filters must be able to protect the enclosure at the worst-case level of contamination anticipated. Once the system is installed, adequate preventive maintenance is crucial. Filters must be cleaned or replaced regularly, or means must be provided for continuous monitoring of the filter condition.

In order to prevent choking of airflow, it is important for the filter inlet opening to be at least as large as the total area of all air outlets. Inlet and outlet areas should be determined after allowance for impedance of grille materials or other barriers.

Air inlets and outlets should be as far apart as possible, so the air is forced to circulate through all heat-producing components. All air inlets should be filtered, whether the air enters through a fan or blower, or directly into the cabinet for exhausting, when pressurization is not feasible.

FILTERS (STANDARD) Filters used with typical electronic equipment cooling devices are usually the viscous-impingement type and are approximately 65% efficient. They utilize fibers that have been coated with a nondrying, tacky substance which traps particulates as air is drawn through. Usually constructed of aluminum foil or flock-coated pleated wire screen, the filters can be cleaned, recoated and re-used indefinitely. Often, filters of this type are used as pre-filters in multiple filter systems to extend the service life of high efficiency or absolute filters.

FILTERS (HIGH EFFICIENCY) High efficiency or absolute filters are available in efficiencies ranging up to 99.97% on 0.3 micron size particles. The filter media is a pleated paper which operates as a strainer, since its openings are physically smaller than the particulates it is designed to intercept. This type of filter offers relatively high resistance to airflow and is employed only where more common filter types are incapable of providing acceptable levels of protection. In applications where such filters are required, provision must be made for adequate airflow to overcome the higher resistance in addition to the cooling airflow needed. These filters are not offered in our standard products.

FLOW MONITORS Where higher levels of contamination exist or can develop rapidly, filtered cooling air packages should be equipped with some form of flow monitor. In the event of a reduction in air delivery below a minimum acceptable level due to a clogged filter, a flow-sensing or temperature-sensing device triggers warning alarms or shuts down effected equipment.

Pressure differential switches, which respond to pressure drops across an air filter, are often employed, as are simple vane-type airflow velocity sensors or thermostatic over-temperature detectors located at equipment hot spots. At times, flow-sensing and temperature-sensing devices are employed in combination. In this way, relatively low airflows are accepted when the ambient temperature is low.

At higher ambient temperatures, reduced airflow, resulting in excessive component temperature, activates the warning device or shuts off power. This arrangement permits maximum filter utilization and safety to the equipment.

The need for flow monitoring should be evaluated carefully because of the added cost of the various devices required.

FORCED CONVECTION COOLING (or Open Loop Ambient Air Cooling) An industry term that describes an air system used to cool a chamber with just the available air surrounding the product.

FORCED VENTILATION vs. CLOSED-LOOP COOLING If ambient air is cool and clean enough, use it. If the ambient is too hot, dirty or corrosive, a closed-loop system is needed. A heat exchanger is usually a lower-cost choice than an air conditioner. See if it will do the job. Don't over-cool. Don't oversize the cooling equipment.

HEAT EXCHANGERS Heat exchangers are recommended to cool equipment which can tolerate operating temperatures moderately higher than ambient, while air conditioners are required where equipment temperatures must be maintained below ambient.

In applications where airborne contaminants pose a threat to electronic components, the enclosure interior must be isolated from the external environment. For such applications, a sealed enclosure, with a heat exchanger or an air conditioner is required.

For installations that can operate at above-ambient temperatures, heat exchangers provide moderate-cost closed-loop cooling. Available in both air-to-air and water-to-air versions, there are models covering a wide range of cabinet sizes and performance capacities. Depending upon the model selected and the heat load, near-ambient to moderately-above-ambient temperatures can be achieved.

For applications that can utilize heat exchangers, the advantages compared with air conditioners include:

- Lower initial cost
- Lower power consumption
- Simpler construction
- Fewer operating components
- Lighter weight

HEAT EXCHANGERS (AIR-TO-AIR) Advanced air-to-air heat exchanger designs for cooling enclosures include two types of heat transfer methods. One design consists of a finned-tube coil which contains liquid refrigerant. The warm air exhausted from the equipment cabinet to the heat exchanger is directed past the coil, causing the refrigerant to

boil and absorb heat. The resultant refrigerant vapor rises to the upper portion of the tubes, where the heat is removed by the cooler ambient air and the refrigerant condenses back to liquid, completing the cooling cycle in a continuous process.

The most recent developments in enclosure heat exchanger design employ high-efficiency heat transfer elements fabricated of embossed convoluted metal foil or thin-film polymer material, constructed into two totally separate air paths. The air leaving the hot enclosure is directed through one side of the exchanger, where the heat passes through the element walls into the ambient-side air stream and is dissipated.

Figure 1 illustrates heat transfer in air-to-air heat exchanger applications.

HEAT EXCHANGERS (WATER-TO-AIR) If ambient air cannot be utilized directly as a cooling medium, another cost-effective method of cooling is a water-to-air system (Figure 2). Water is used to remove heat from air circulated within the electrical enclosure.

Cooling water is circulated through a finned-tube coil, which is installed in a compartment isolated from the enclosure to protect the contents from possible leakage of water. As the heat-laden air circulates through the coil, the heat is absorbed by the water and carried away, in a continuous process.

Water-to-air systems are easy to install and usually require minimum maintenance. The water used must be reasonably clean and cold enough to ensure proper operation of the cooling system under the most severe anticipated conditions.

In cases where sufficiently cold water is available, below ambient-temperature cooling can be achieved.

HEAT LOAD TRANSFER The amount of heat that is conducted through the exposed area of the enclosure from the warmer to the cooler space. Heat load transfer can be a heat gain, or a heat loss to the cabinet, depending on the conditions.

If the air outside the cabinet is warmer than the air inside the cabinet, the heat is moving through the cabinet and increasing the total heat load - this will require a larger capacity air conditioner.

If the air outside the cabinet is cooler than the air inside the cabinet, the heat is moving through the cabinet and decreasing the total heat load - this will require a smaller capacity air conditioner.

HOT GAS BYPASS VALVE A refrigerant metering device that allows some of the hot compressor discharge gas to flow into the evaporator. Its function is to prevent the coil from freezing during low load conditions and provide uninterrupted cooling. (See Temperature Control)

HUMIDITY See Relative Humidity

INTERNAL HEAT LOAD The heat generated by the components inside the cabinet.

INSULATED ENCLOSURES Insulated enclosures are recommended for outdoor applications, to minimize the additional heat load caused by the sun's rays. It is best to consult your insulation supplier to select the correct material with the right thermal, flame and electrical ratings for your application. In general, a thin layer (about 1/2 inch) of foam insulation, with the proper flame rating, is sufficient for most applications. (See Non-Metallic Enclosures)

LATENT HEAT The energy in air that is reduced when water is removed in the form of condensation (see Sensible Heat).

NEMA - National Electrical Manufacturers Association - Your equipment may require a NEMA rating to comply with local codes. See page 9 for chart of NEMA Enclosure Ratings. Air conditioners typically carry an agency marking such as UL, (Underwriters Laboratories) which designates the environmental hazard from which the contents are being protected. This marking should be matched to the enclosure to be cooled. Typical examples include NEMA 12, (indoor use, protection from dust and dripping liquids), NEMA 3R, (outdoor use and rain proof) and NEMA 4/X (outdoor or indoor use, protection from wash-down and corrosive environments). Depending upon the NEMA enclosure type, an air conditioner can be provided to operate in most locations. Locations subject to dust, dripping liquids, rain, wash down and corrosive atmospheres can utilize these "Special Purpose Air Conditioners."

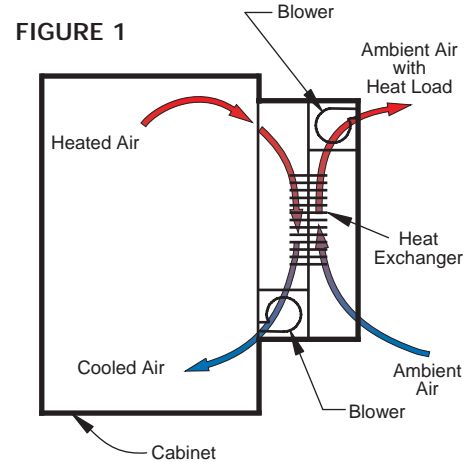

In an air-to-air heat exchanger, heat from air surrounding the components is removed by a specially designed heat transfer element before being routed back into the enclosure.

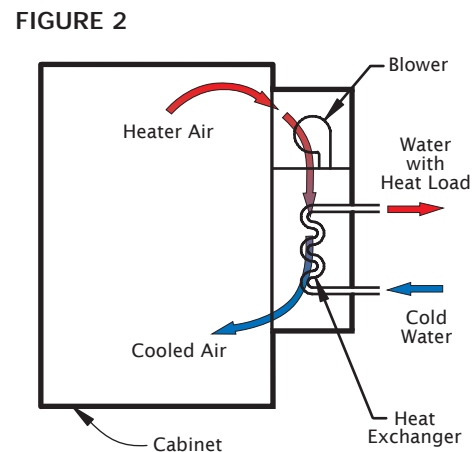

A water-to-air heat exchanger works by transferring heat of internal air to circulating water, resulting in cooled air which is recirculated throughout the equipment enclosure.

NON-METALLIC ENCLOSURES Although plastics have better insulating properties than metal, a layer of insulation is still recommended for outdoor applications. (See Insulated Enclosures)

RADIO FREQUENCY INTERFERENCE (RFI) “Noise” that is accidentally generated by electrical products that interferes with the normal transmission and reception of radios and other equipment that uses radio waves.

RELATIVE HUMIDITY A unit of measure to describe the amount of water (moisture) in air. It is described in percent, i.e. %RH - over 80%RH is very humid, and below 30% is very dry. (See Condensation)

SENSIBLE HEAT The thermal energy in air that is measured by a change in temperature. (see Latent Heat)

SOLAR LOAD or **SUN LOAD** The heat from the sun must be considered when identifying the total heat load on a system. This solar load can be minimized if the equipment cabinet is shielded from the direct rays of the sun. If this is not possible painting the cabinet a light color and adding insulation should be considered. If none of these alternatives are possible, the capacity must be increased to address this additional heat load. In the southern USA, this affect can be significant. In the northern USA, this affect might be negligible. See the formula in section 4A, to evaluate this issue.

STATIC PRESSURE A method used to quantify the air pressure created by a fan or blower wheel. Low static pressure exists at the outlet of a fan that is blowing into an open air space. High static pressure is created when the same fan is blowing into a restrictive, closed compartment. High static pressure is an indication of low airflow, and possibly poor cooling. If the components in a product are inherently very congested, the air flow through them will be restricted and create high static pressure. This condition can be overcome with an alternate blower wheel housing design. Typically a larger motor is needed to overcome this condition.

TEMPERATURE CONTROL Typical refrigeration and air conditioning systems control temperature by on/off compressor cycling as air temperatures fluctuate between minimum and maximum thermostat settings. Compressor start-up often introduces substantial transient noise into the circuit powering the equipment to be cooled. Thermostat or relay operation results in electromagnetic interference. Both of these factors can adversely affect the function of electronic equipment. On/off compressor control necessitates choosing between large temperature excursions or frequent compressor cycling.

Furthermore, frequent start/stop operation exposes internal compressor components to electrical and mechanical strains not encountered during continuous operation. The use of electrical controls to handle high compressor start-currents results in eventual erosion of the control contacts themselves.

In order to eliminate the possibility of these problems, KOOLTRONIC Air Conditioners feature a continuously operating compressor and non-electric proportional control system, which result in more stable equipment temperatures and prolonged life for the compressor and the control system. Both blowers and the compressor start simultaneously with the application of power to the unit, and continue to operate until power is removed at the time of equipment shutdown.

The Hot Gas Bypass Control Valve permits refrigerant to be injected into the evaporator coil. This high-temperature gas presents an artificial heat load and permits the effective cooling rate to be varied as necessary to maintain a constant return air temperature back to the enclosure. This control also prevents evaporator freeze-ups during periods of low heat load or low ambient temperature.

Although the above control system works effectively at most times, there are instances of over-cooling due to low heat load or low ambient temperature. In order to prevent that condition, Low Temperature Control thermostats and EMI/RFI suppressors have been added to all KOOLTRONIC Air Conditioners.

When activated, the Low Temperature Control shuts off the compressor and condenser (ambient side) blowers. The evaporator (enclosure side) blowers continue to circulate the air through the enclosure and air conditioner. When the air temperature again reaches the level at which cooling is needed, the compressor and condenser blowers resume operation.

UNDERWRITERS LABORATORIES, INC. (UL) The leading third party product safety organization in the United States, the largest in North America and the leading quality system registrar headquartered in the United States. Providing product safety verification services for more than a century, the UL Mark is one of the world’s most familiar safety certification symbols. The Canadian Standards Association (CSA) provides similar service in Canada. Recently UL and CSA have been working cooperatively and have adopted joint procedures, standards and marks.

VAPOR COMPRESSION REFRIGERATION CYCLE (See Air Conditioner)

WATT A unit of measure for electrical power. Watts are also used to quantify the amount of heat in a system, because 1 watt will convert to 3.413 BTU’s.